

SPACERS

Drawings are not to scale

Metric spacers are black oxidized

Slots and holes are centered unless otherwise noted

Most spacers are etched on the side with thickness

DSCP082 Series Spacers

DSC Part No.	Thickness	Other part numbers
DSCP082-E320	.32 inch	FSD 40881

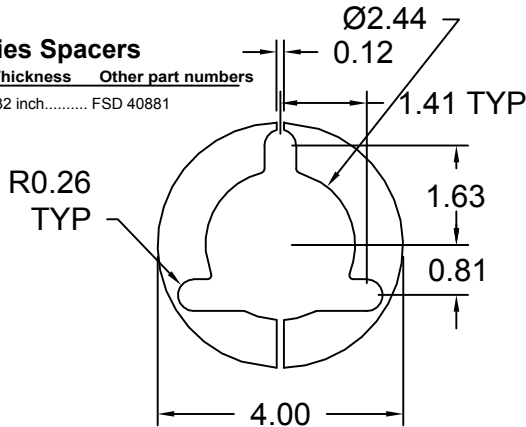

DSCP083 Series Spacers

DSC Part No.	Thickness	Other part numbers
DSCP083-E320	.32 inch	FSD 40920

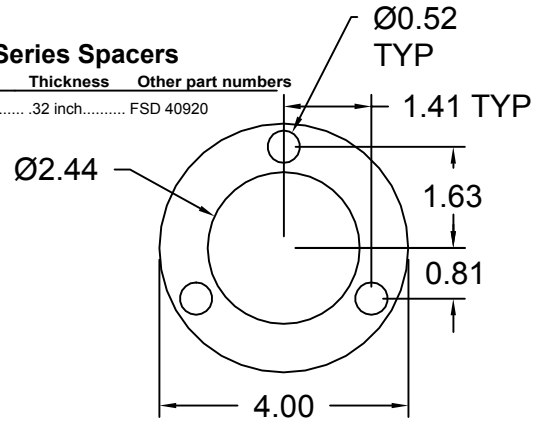

DSCP084 Series Spacers

DSC Part No.	Thickness	Other part #s	DSC Part No.	Thickness	Other part #s
DSCP084-M200	2.00mm	D113022, D113085	DSCP084-M562	5.62mm	D113043
DSCP084-M220	2.20mm	D113086	DSCP084-M575	5.75mm	D113044
DSCP084-M225	2.25mm	D113023	DSCP084-M580	5.80mm	D113104
DSCP084-M240	2.40mm	D113087	DSCP084-M588	5.88mm	D113045
DSCP084-M250	2.50mm	D113024	DSCP084-M600	6.00mm	D113046, D113105
DSCP084-M260	2.60mm	D113088	DSCP084-M612	6.12mm	D113047
DSCP084-M275	2.75mm	D113025	DSCP084-M620	6.20mm	D113106
DSCP084-M280	2.80mm	D113089	DSCP084-M625	6.25mm	D113048
DSCP084-M300	3.00mm	D113026, D113090	DSCP084-M638	6.38mm	D113049
DSCP084-M320	3.20mm	D113091	DSCP084-M640	6.40mm	D113107
DSCP084-M325	3.25mm	D113027	DSCP084-M650	6.50mm	D113050
DSCP084-M340	3.40mm	D113092	DSCP084-M660	6.60mm	D113108
DSCP084-M350	3.50mm	D113028	DSCP084-M662	6.62mm	D113051
DSCP084-M360	3.60mm	D113093	DSCP084-M675	6.75mm	D113052
DSCP084-M375	3.75mm	D113029	DSCP084-M680	6.80mm	D113109
DSCP084-M380	3.80mm	D113094	DSCP084-M688	6.88mm	D113053
DSCP084-M400	4.00mm	D113030, D113095	DSCP084-M700	7.00mm	D113054, D113110
DSCP084-M412	4.12mm	D113031	DSCP084-M712	7.12mm	D113055
DSCP084-M420	4.20mm	D113096	DSCP084-M720	7.20mm	D113111
DSCP084-M425	4.25mm	D113032	DSCP084-M725	7.25mm	D113056
DSCP084-M438	4.38mm	D113033	DSCP084-M738	7.38mm	D113057
DSCP084-M440	4.40mm	D113097	DSCP084-M740	7.40mm	D113112
DSCP084-M450	4.50mm	D113034	DSCP084-M750	7.50mm	D113058
DSCP084-M460	4.60mm	D113098	DSCP084-M760	7.60mm	D113113
DSCP084-M462	4.62mm	D113035	DSCP084-M775	7.75mm	D113060
DSCP084-M475	4.75mm	D113036	DSCP084-M780	7.80mm	D113114
DSCP084-M480	4.80mm	D113099	DSCP084-M788	7.88mm	D113061
DSCP084-M488	4.88mm	D113037	DSCP084-M800	8.00mm	D113062, D113115
DSCP084-M500	5.00mm	D113038, D113100			
DSCP084-M512	5.12mm	D113039			
DSCP084-M520	5.20mm	D113101			
DSCP084-M525	5.25mm	D113040			
DSCP084-M538	5.38mm	D113041			
DSCP084-M540	5.40mm	D113102			
DSCP084-M550	5.50mm	D113042			
DSCP084-M560	5.60mm	D113103			

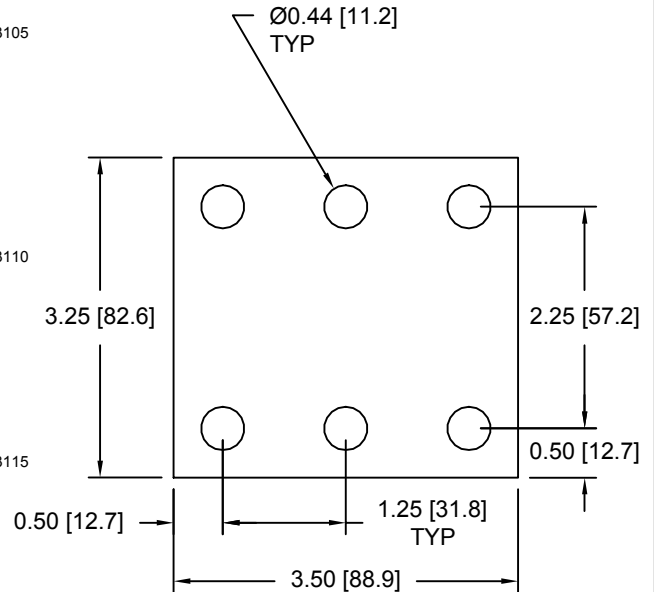

DSCP085 Series Spacers

DSC Part No.	Thickness	Other part #s	DSC Part No.	Thickness	Other part #s
DSCP085-M300	3.00mm	D233007	DSCP085-M640	6.40mm	D233024
DSCP085-M320	3.20mm	D233008	DSCP085-M660	6.60mm	D233025
DSCP085-M340	3.40mm	D233009	DSCP085-M680	6.80mm	D233026
DSCP085-M360	3.60mm	D233010	DSCP085-M700	7.00mm	D233027
DSCP085-M380	3.80mm	D233011			
DSCP085-M400	4.00mm	D233012			
DSCP085-M420	4.20mm	D233013			
DSCP085-M440	4.40mm	D233014			
DSCP085-M460	4.60mm	D233015			
DSCP085-M480	4.80mm	D233016			
DSCP085-M500	5.00mm	D233017			
DSCP085-M520	5.20mm	D233018			
DSCP085-M540	5.40mm	D233019			
DSCP085-M560	5.60mm	D233020			
DSCP085-M580	5.80mm	D233021			
DSCP085-M600	6.00mm	D233022			
DSCP085-M620	6.20mm	D233023			

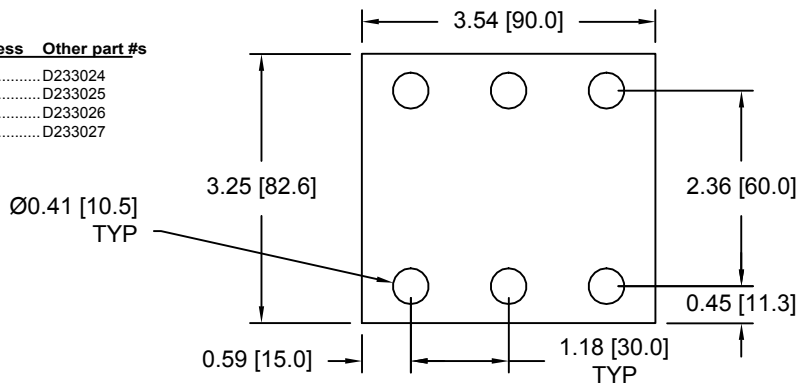

Douglas Stamping Company (248) 542-3940 FAX (248) 542-6342

<http://dougstampco.com> sales@dougstampco.com