

# SPACERS

Drawings are not to scale

Metric spacers are black oxidized

Slots and holes are centered unless otherwise noted

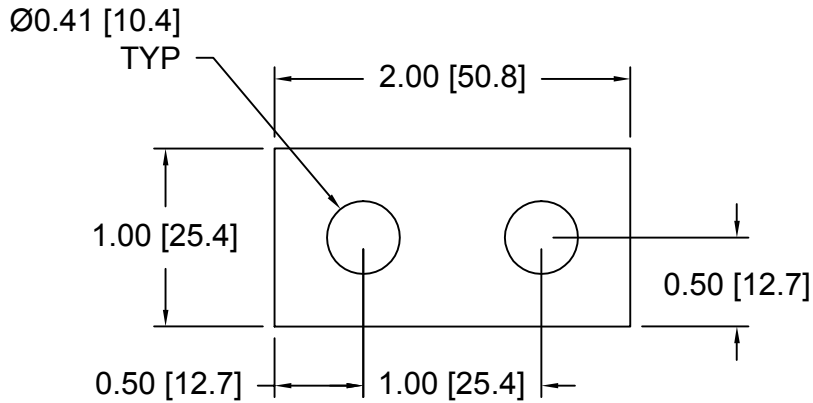

## DSCP086 Series Spacers

DSC Part No.	Thickness	Other part numbers
DSCP086-M300	3.00mm	D101044
DSCP086-M400	4.00mm	D101045
DSCP086-M500	5.00mm	D101046
DSCP086-M600	6.00mm	D101047
DSCP086-M700	7.00mm	D101048
DSCP086-M800	8.00mm	D101049

## DSCP087 Series Spacers

DSC Part No.	Thickness	Other part #s	DSC Part No.	Thickness	Other part #s
DSCP087-M300	3.00mm	ACS630S	DSCP087-M640	6.40mm	ACS664S
DSCP087-M320	3.20mm	ACS632S	DSCP087-M660	6.60mm	ACS666S
DSCP087-M340	3.40mm	ACS634S	DSCP087-M680	6.80mm	ACS668S
DSCP087-M360	3.60mm	ACS636S	DSCP087-M700	7.00mm	ACS670S
DSCP087-M380	3.80mm	ACS638S			
DSCP087-M400	4.00mm	ACS640S			
DSCP087-M420	4.20mm	ACS642S			
DSCP087-M440	4.40mm	ACS644S			
DSCP087-M460	4.60mm	ACS646S			
DSCP087-M480	4.80mm	ACS648S			
DSCP087-M500	5.00mm	ACS650S			
DSCP087-M520	5.20mm	ACS652S			
DSCP087-M540	5.40mm	ACS654S			
DSCP087-M560	5.60mm	ACS656S			
DSCP087-M580	5.80mm	ACS658S			
DSCP087-M600	6.00mm	ACS660S			
DSCP087-M620	6.20mm	ACS662S			

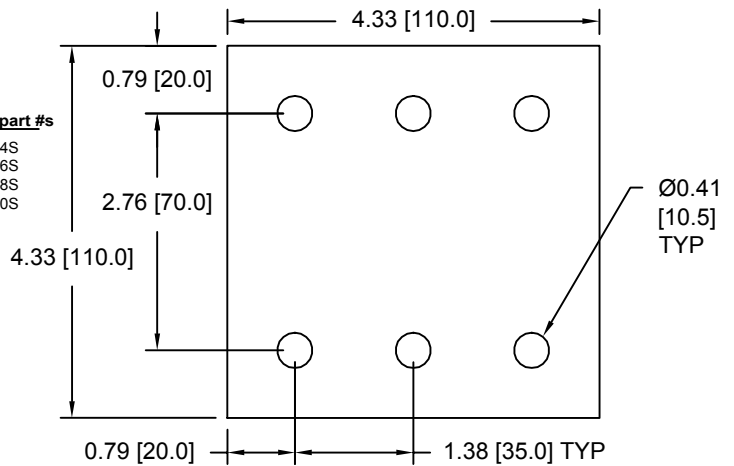

## DSCP088 Series Spacers

DSC Part No.	Thickness	Other part numbers
DSCP088-E250	.25 inch	D113069

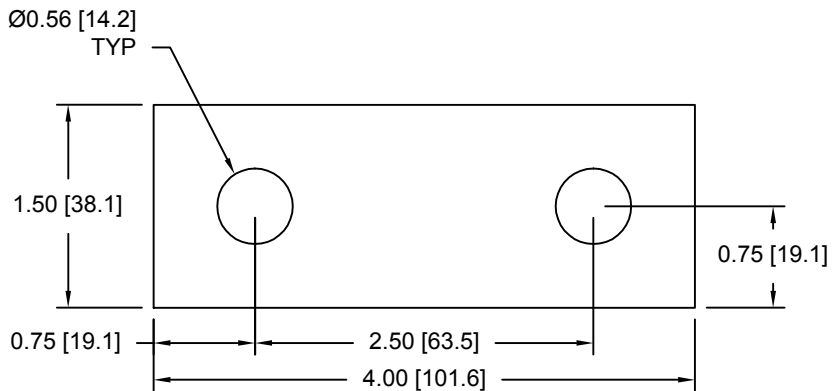

## DSCP089 Series Spacers

DSC Part No.	Thickness	Other part numbers
DSCP089-E250	.25 inch	D113070

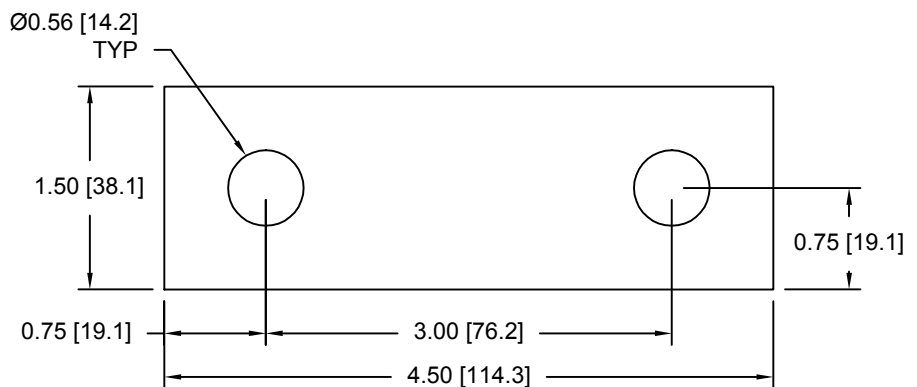

Douglas Stamping Company (248) 542-3940 FAX (248) 542-6342

<http://dougstampco.com> [sales@dougstampco.com](mailto:sales@dougstampco.com)